

### SLIDING HOOK FLYER

For single & double treadle Joy spinning wheels

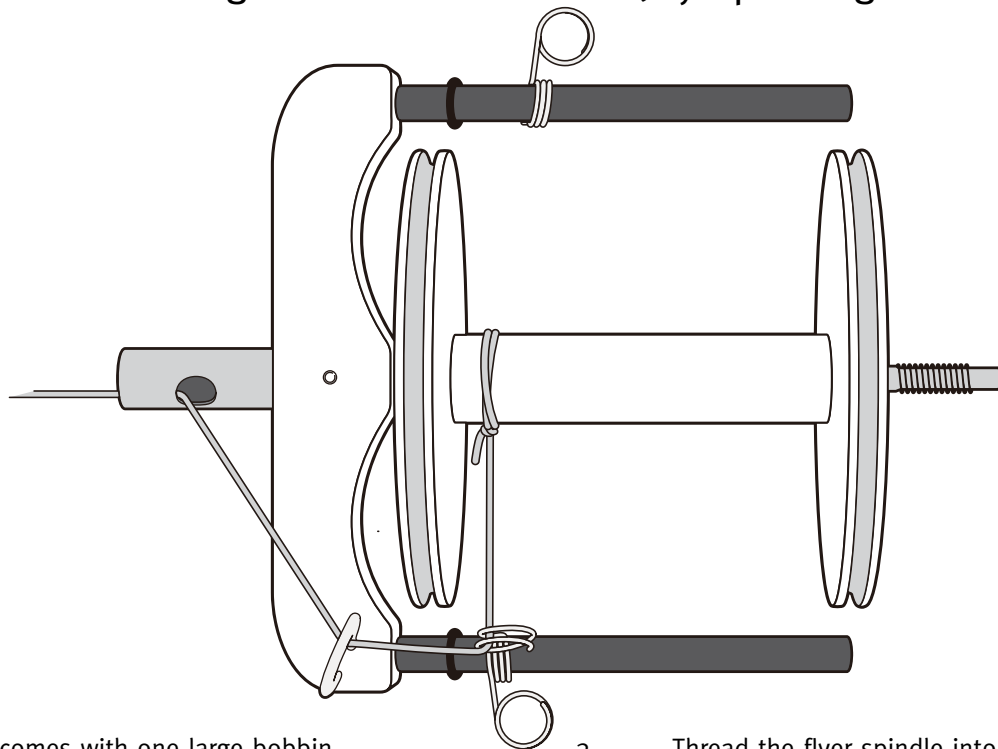

- Flyer comes with one large bobbin.
- Fill your bobbins evenly with the squeeze and slide stainless steel yarn guides.
- Fibreglass arms result in a light and strong flyer.
- The 4 speed pulley allows a wide range of yarns to be spun.

**Ratios**            6            8            11            14            :1

1. Thread the 2 hooks into the pilot holes in the flyer base.
2. Apply a drop of oil to the flyer spindle and slide the bobbin on.  
Ashford spinning wheel oil is ideal for this purpose.

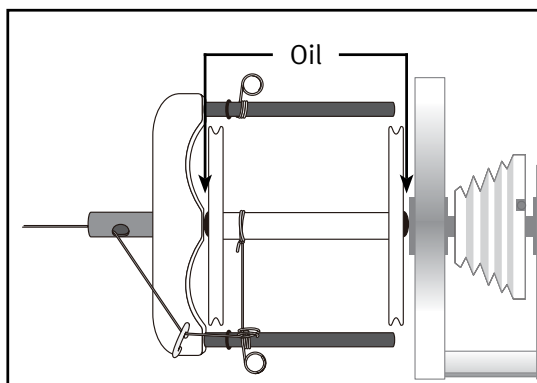

3. Thread the flyer spindle into the top shaft. Hold the flyer whorl with one hand and rotate the flyer clockwise with the other. Take care not to force or overtighten the flyer.

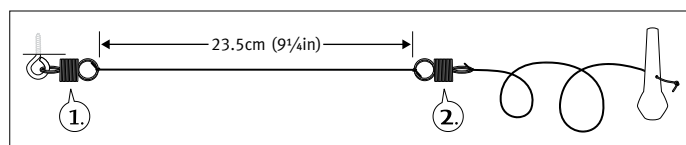

4. Cut 33cm (13ins) off the brake band. Tie one end to the spring attached to the frame and the other to the second spring so that you have 23.5cm (9 1/4 ins) in between the 2 springs.
5. Tie a leader yarn approx. 1.5m / 5' to the bobbin centre and feed it through the yarn guide, around the flyer hook and through the orifice.
6. As your bobbin fills, squeeze and slide the yarn guide to fill your bobbin evenly.

**Happy Spinning!**

*If your new flyer does not thread easily or fully into the top shaft, please refer to the instructions on replacing the top shaft.*

23.5cm (9 1/4 ins)

## REPLACING THE TOP SHAFT JOY ASHFORD SPINNING WHEEL

If your new Sliding Hook Flyer does not thread easily or fully into the top shaft, your wheel was probably made before 2002. Enclosed is a new top shaft and instructions on how to fit it.

### Tools required

⊕ Screwdriver, small hammer, pliers and eye protection.

Before commencing and to avoid frustration please read these instructions carefully and follow the step by step instructions in the **correct** sequence.

1. Remove the two back E-Clips from top shaft and crank.

**Caution:** the E-Clips are under tension and can fly off. **Wear eye protection.**



2. Remove the four screws that retain the back frame to the four dowel spacers.



3. Remove the three screws that attach the back frame to the base.

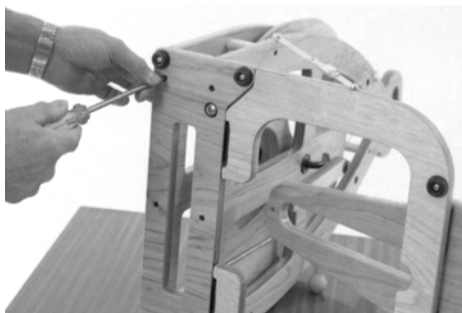

4. Use a hammer and nail to tap the flyer shaft and crank forward until they are free of the bearings in the back frame.



5. Lift the back frame away from the flyer shaft and crank.



6. Carefully remove the E-Clip from the front of the flyer shaft and slide the shaft out. Carefully remove the E-Clip from in front of the pulley and slide the pulley off the shaft. Tap the tension pin out of the original flyer shaft and tap it into the new flyer shaft. Slide the pulley onto the new flyer shaft until the groove engages the tension pin. Then secure with an E-Clip. Fit the new shaft into the frame and secure with an E-Clip.

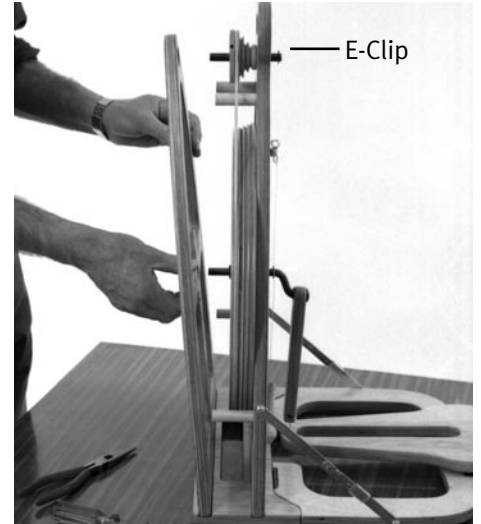

7. Place the drive belt around the wheel and pulley. Then replace the back frame into position carefully sliding the flyer and crank back through the ball bearings. **Note:** Take care not to push the ball bearings out of the plastic bearing housings.

8. Replace the E-Clips onto the grooves in the flyer shaft and crank. **Wear eye protection.** Ensure the E-Clips locate into the bottom of the grooves. It may be necessary to squeeze the front and back frame together to ensure the crank projects through the bearing.



9. Replace the screws holding the back frame to the base and dowel spacers.

10. Thread the flyer into the shaft.

**You are now ready to spin.**

01022011V2