

WARPING MILL

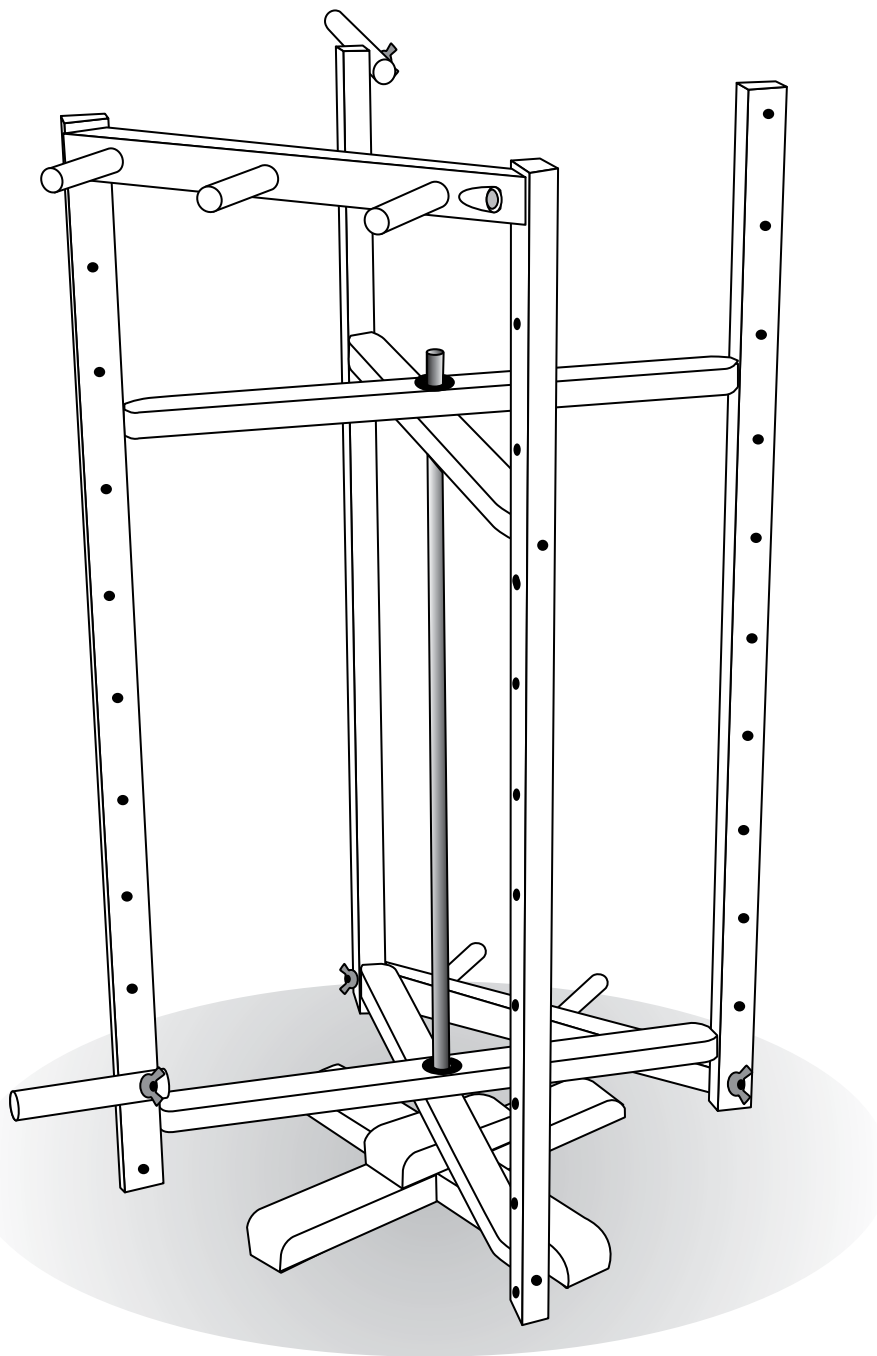

Step 1

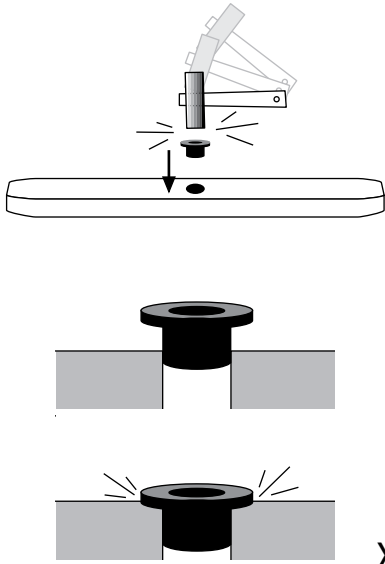

X4

Step 2

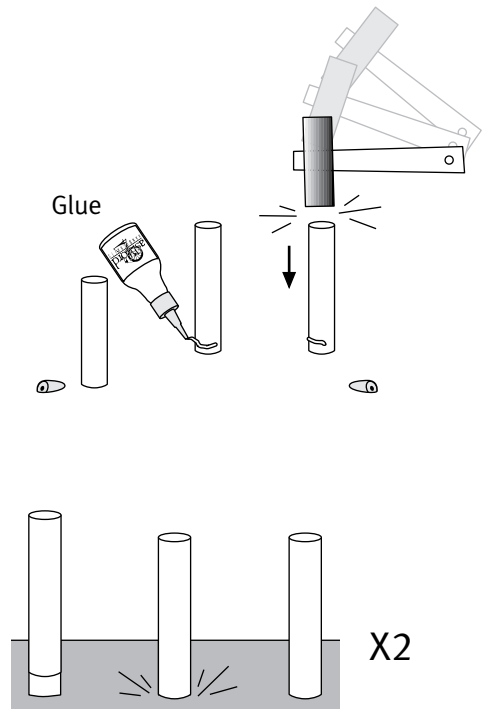

X2

Step 3

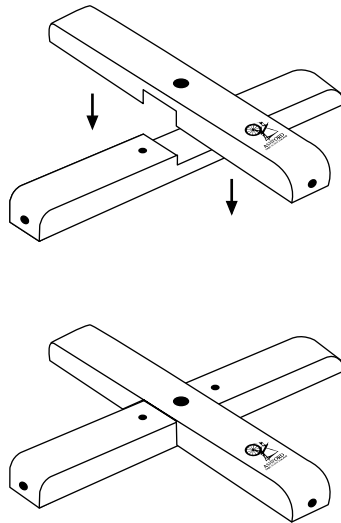

Step 4

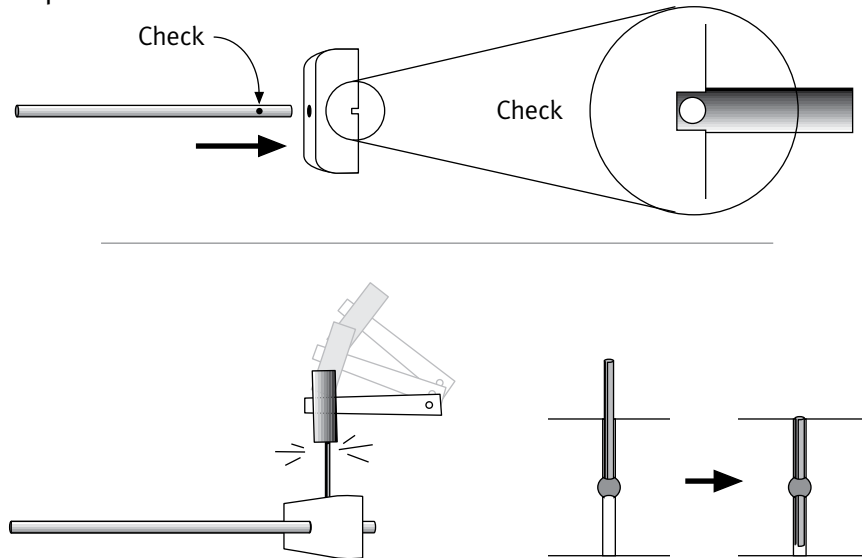

Step 5

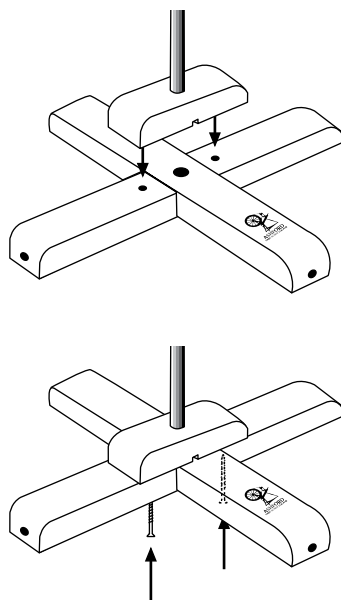

Step 6

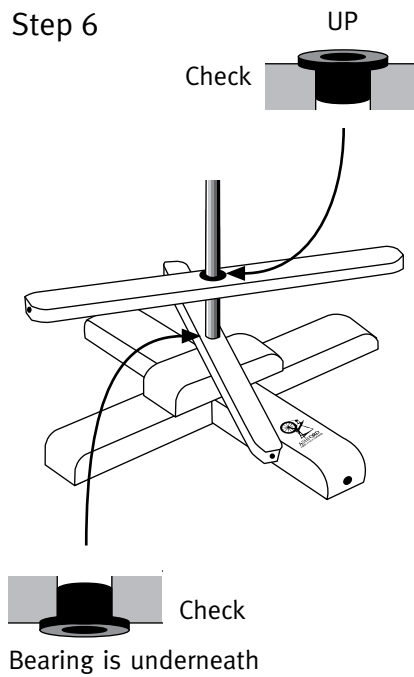

Bearing is underneath

Step 7

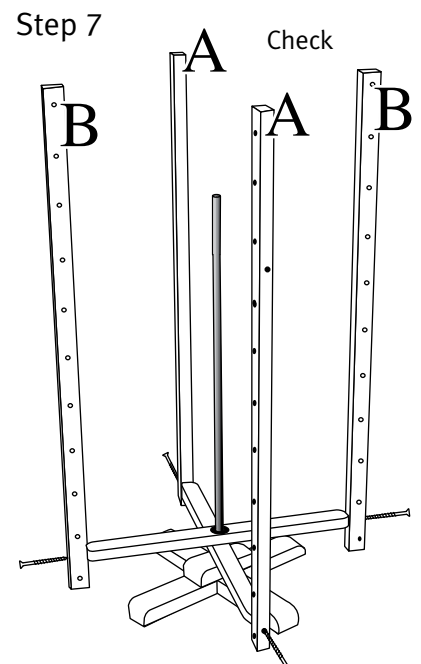

Step 8

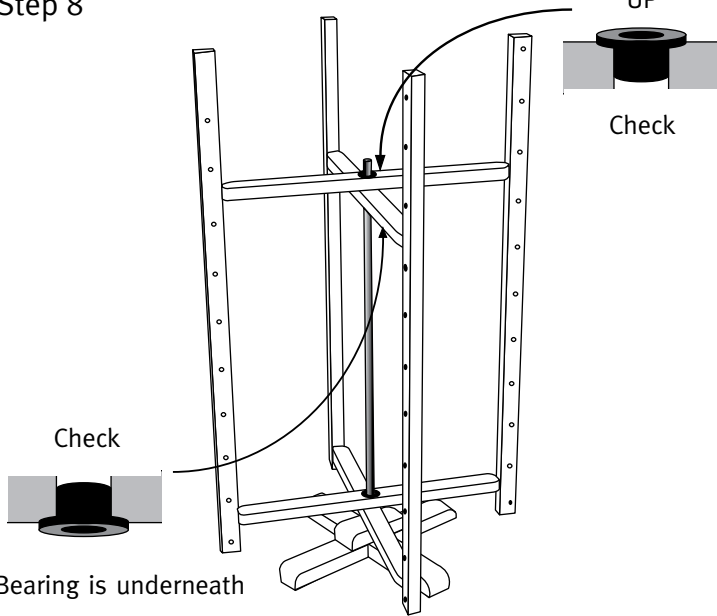

Step 9

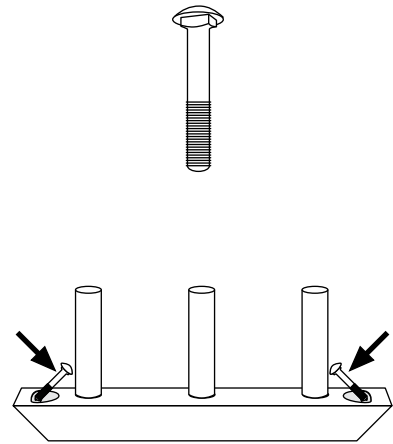

Step 10

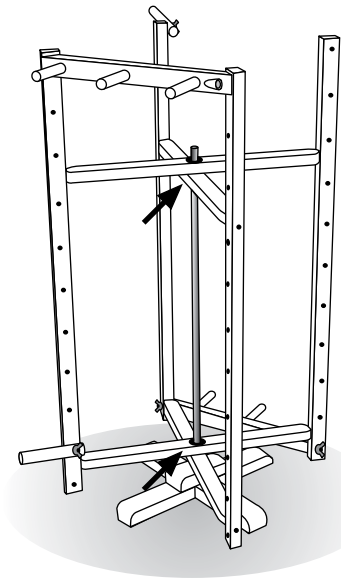
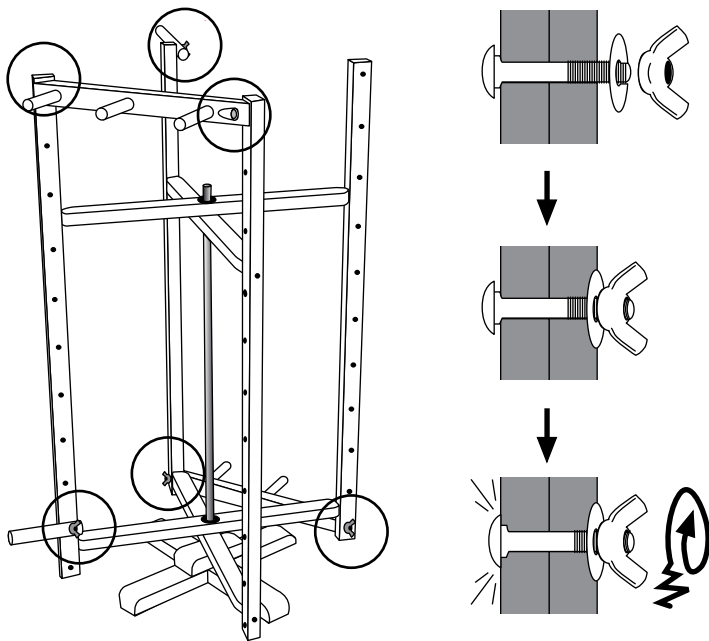

*Optional accessory Ashford Spinning Wheel Oil

